

DOORS SECTIONS

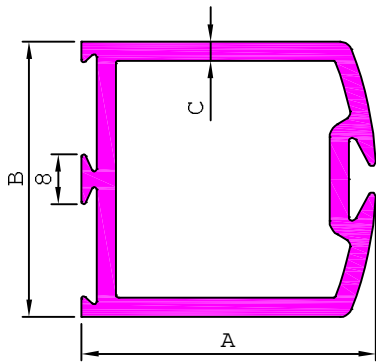

SL. No.	Section No.	A	B	C	Weight kg/m
1	19543	47.62	44.45	0.80	0.493
2	19538	47.62	44.45	1.18	0.667
3	19547	47.62	44.45	1.35	0.759
4	19526	47.62	44.45	1.62	0.881
5	19569	47.62	44.45	2.02	1.052
6	19501	47.62	44.45	3.10	1.505
7	19585	50.00	44.50	1.90	1.030
8	19554	50.00	44.50	2.50	1.292
9	19516	53.70	44.45	2.30	1.238
10	19600	85.00	44.45	1.40	1.037
11	19550	85.00	44.45	1.56	1.139
12	19572	85.00	44.45	1.80	1.301
13	19560	85.00	44.45	2.00	1.417
14	19509	85.00	44.45	3.00	2.050
15	19592	85.00	44.45	3.26	2.200

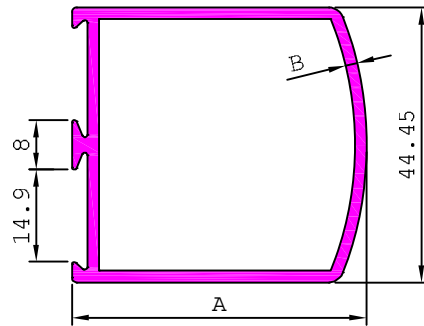

SL. No.	Section No.	A	B	Weight kg/m
1	19570	47.62	1.90	0.911
2	19502	47.62	2.82	1.293
3	19518	53.70	2.30	1.173

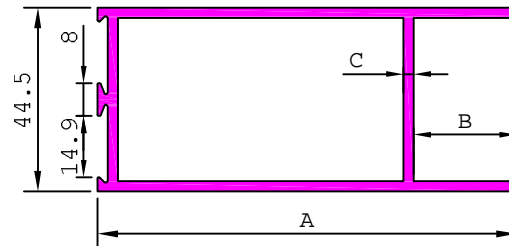

SL. No.	Section No.	A	B	C	Weight kg/m
1	19576	47.62	10.15	0.99	0.537
2	19528	47.62	10.16	1.74	0.881
3	19571	47.62	10.16	1.95	0.974
4	19503	47.62	10.16	3.18	1.501
5	19539	47.62	10.20	1.40	0.719
6	19555	50.00	9.50	2.50	1.247
7	19580	83.50	9.50	1.49	1.055
8	19581	83.50	9.50	2.00	1.384
9	19593	83.50	9.50	3.27	2.172
10	19563	85.00	10.00	2.70	1.843
11	19544	95.25	25.40	0.89	0.719
12	19540	95.25	25.40	1.16	0.911
13	19529	95.25	25.40	1.70	1.301
14	19505	95.25	25.40	2.00	1.519
15	19556	101.60	25.00	2.50	1.943
16	19534	114.30	10.15	1.35	1.190
17	19567	114.30	10.15	1.75	1.515
18	19559	114.30	10.15	1.95	1.674
19	19573	114.30	10.15	2.15	1.836
20	19591	114.30	10.15	2.42	2.051
21	19510	114.30	10.15	3.18	2.646
22	19541	114.30	25.40	1.29	1.139
23	19530	114.30	25.40	1.49	1.302
24	19574	114.30	25.40	2.15	1.824
25	19511	114.30	25.40	3.18	2.646
26	19517	150.00	25.40	2.20	2.376
27	19584	150.00	25.40	3.10	3.181

19504

1.324 kg/m

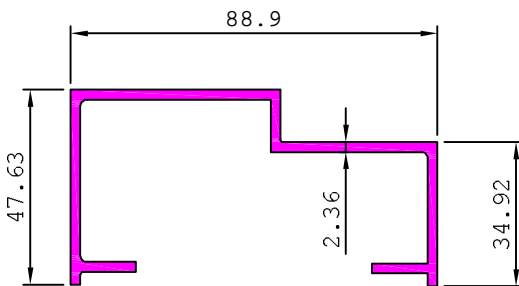

DOORS SECTIONS

19514

1.415 kg/m

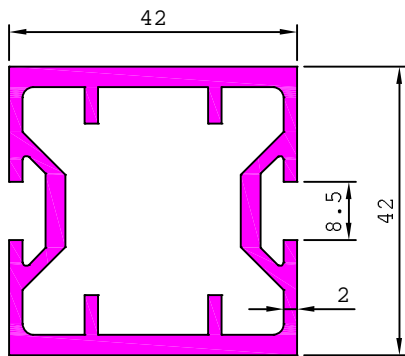

19515

3.186 kg/m

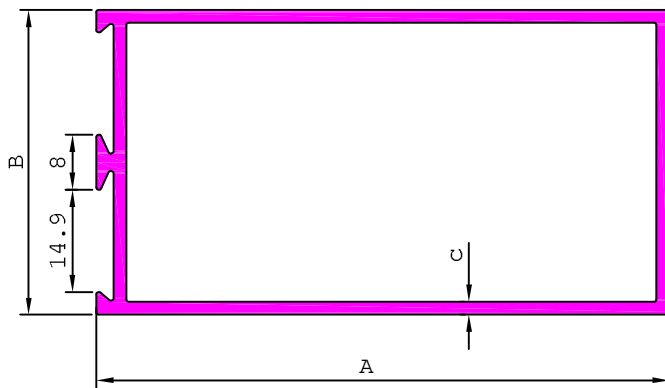
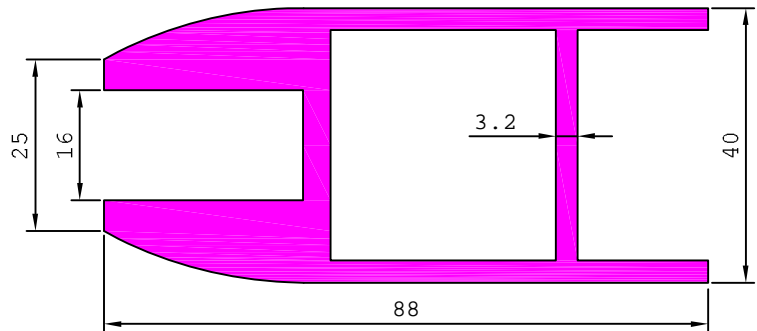

Sl. No.	Section No.	A	B	C	Weight kg/m
1	19542	47.62	44.45	1.14	0.607
2	19527	47.62	44.45	1.74	0.881
3	20071	47.62	44.45	1.88	0.943
4	20061	47.62	44.45	2.17	1.072
5	19512	47.62	44.45	3.00	1.426
6	19548	47.62	44.50	1.42	0.738
7	19549	83.50	44.45	1.62	1.139
8	19582	83.50	44.45	1.87	1.300
9	19508	83.50	44.45	3.00	2.107
10	19568	104.00	44.45	1.80	1.600

19519

1.921 kg/m

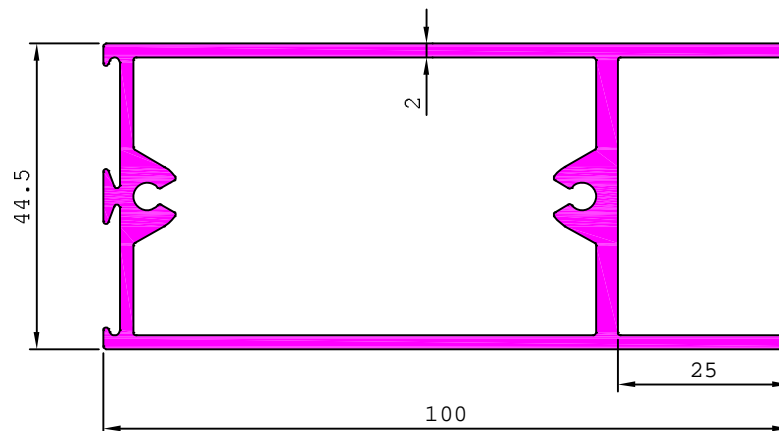

DOORS SECTIONS

19520

1.359 kg/m

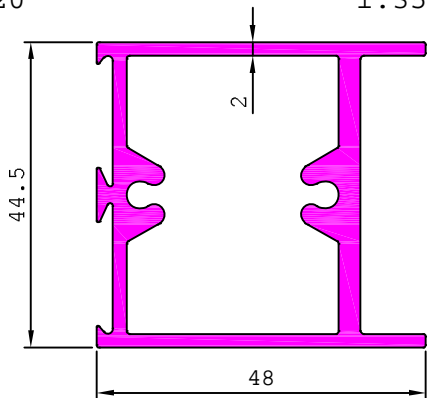

19524

0.820 kg/m

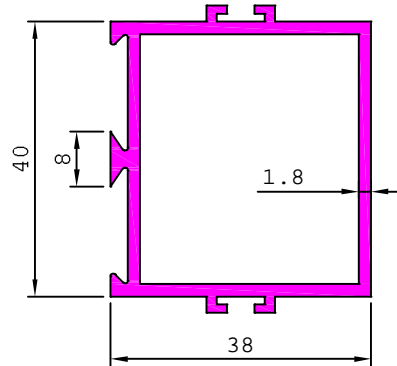

19531

0.924 kg/m

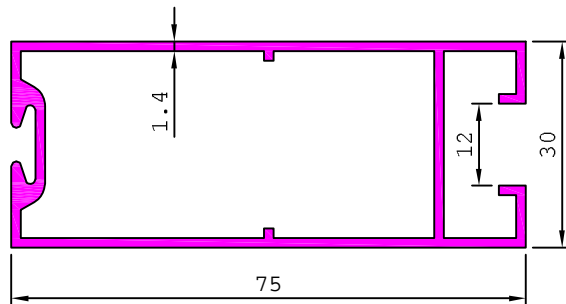

19533

2.863 kg/m

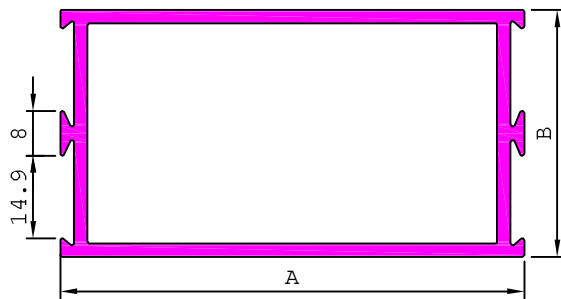
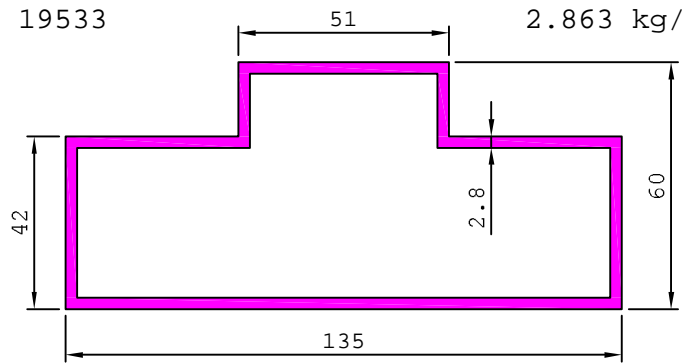

SL. No.	Section No.	A	B	C	Weight kg/m
1	19575	49.91	44.45	1.60	0.882
2	19599	83.50	44.45	1.40	1.052
3	19551	83.50	44.45	1.54	1.139
4	19535	83.50	44.45	1.70	1.243
5	20111	83.50	44.45	2.11	1.497
6	19525	83.50	44.45	2.40	1.679
7	19583	83.50	44.45	3.18	2.145
8	19564	100.00	44.45	2.00	1.603
9	19596	150.00	44.45	3.00	3.116

19536

1.677 kg/m

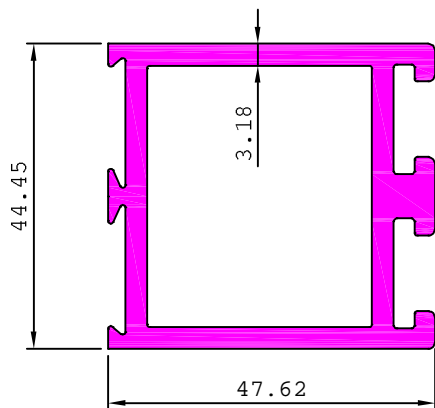

19537

1.911 kg/m

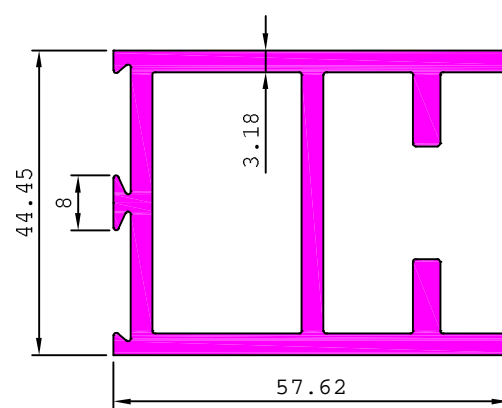

DOORS SECTIONS

19545

2.959 kg/m

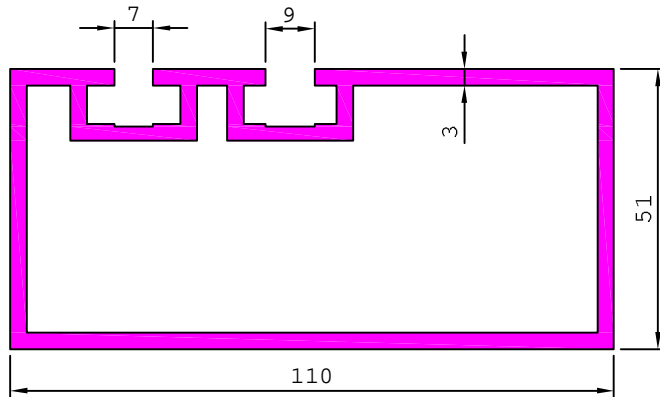

19552

1.116 kg/m

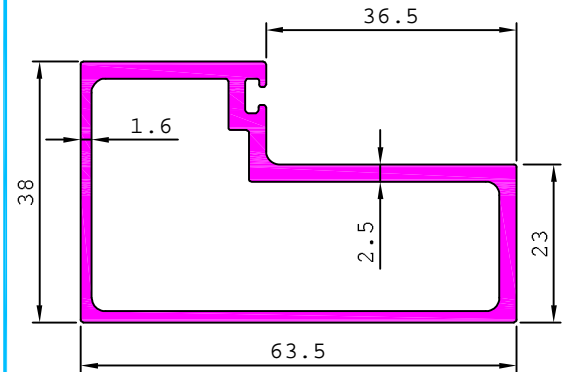

19546

3.060 kg/m

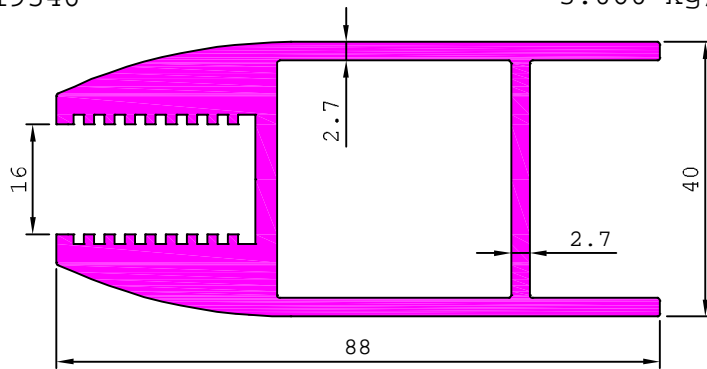

19557

1.248 kg/m

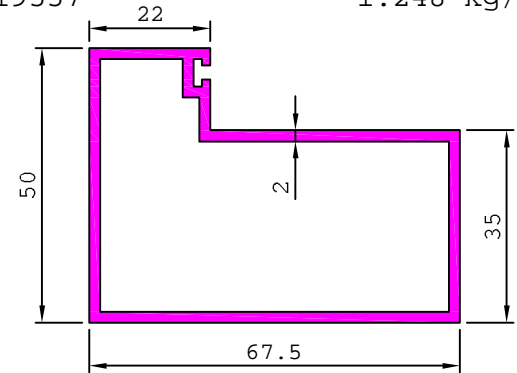

19553

1.800 kg/m

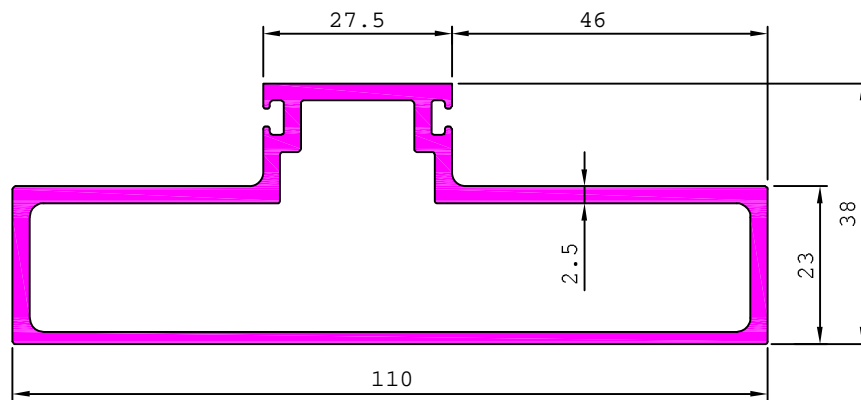

19558

1.926 kg/m

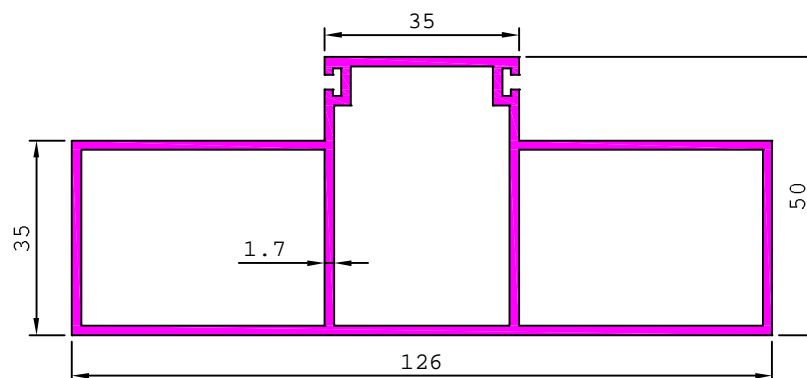

DOORS SECTIONS

19565

1.281 kg/m

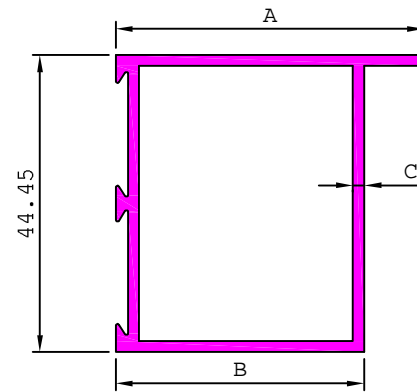
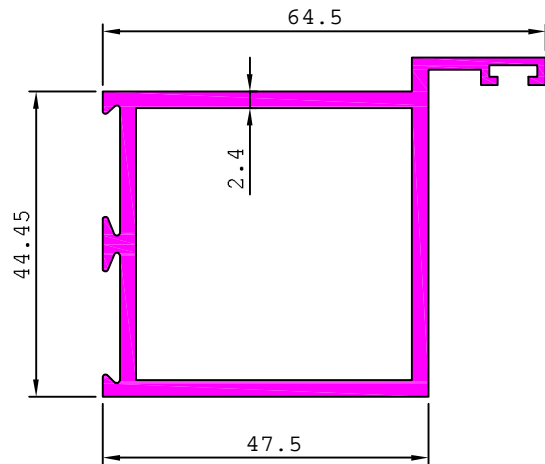

SL. No.	Section No.	A	B	C	Weight kg/m
1	19579	47.50	38.25	1.60	0.769
2	19566	47.00	38.00	2.40	1.102
3	19590	83.50	73.35	1.55	1.053

19578

1.006 kg/m

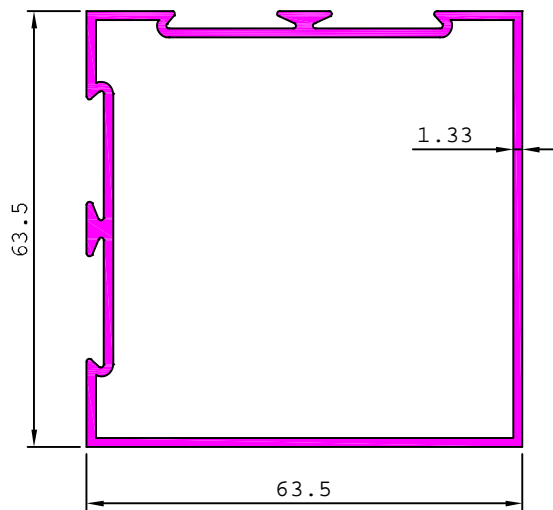

19587

0.441 kg/m

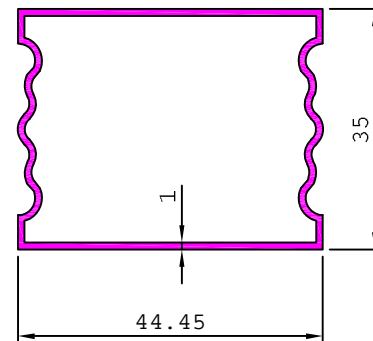

19586

1.013 kg/m

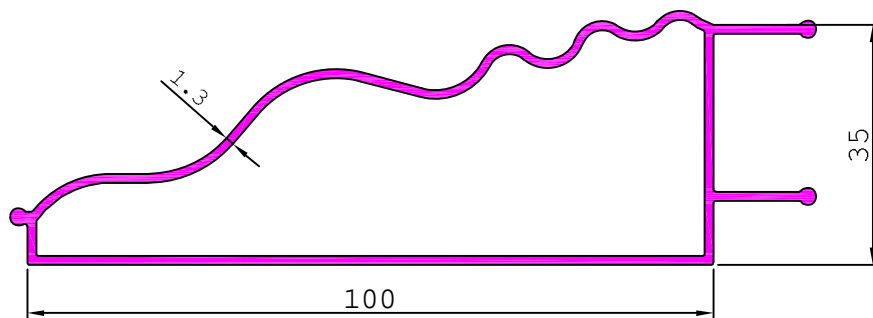

DOORS SECTIONS

19589 0.777 kg/m

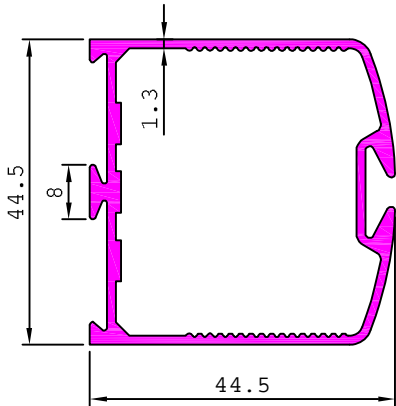

19588 1.003 kg/m

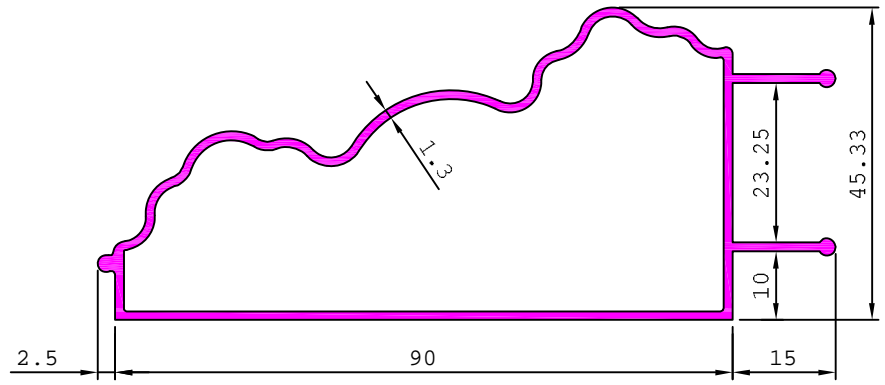

19594 1.285 kg/m

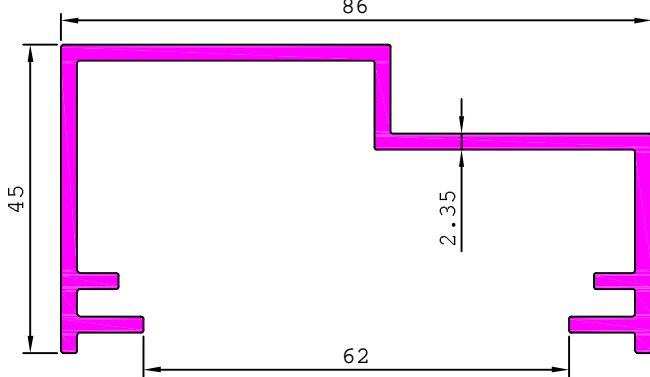

19595 2.325 kg/m

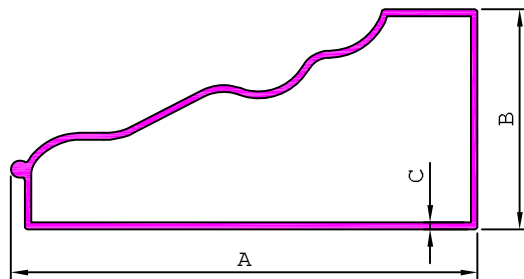
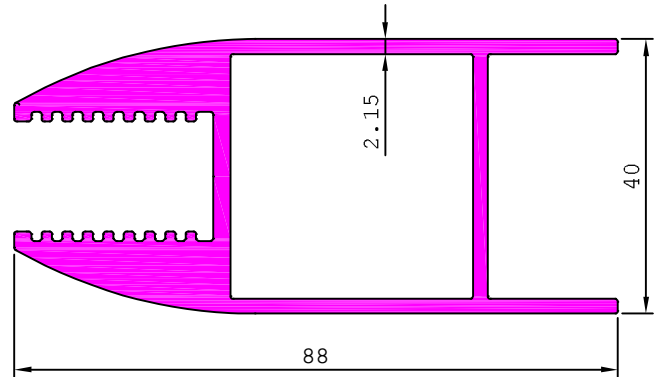

SL. No.	Section No.	A	B	C	Weight kg/m
1	19607	68.00	32.00	0.80	0.397
2	19597	68.00	32.00	1.00	0.492

19598 0.632 kg/m

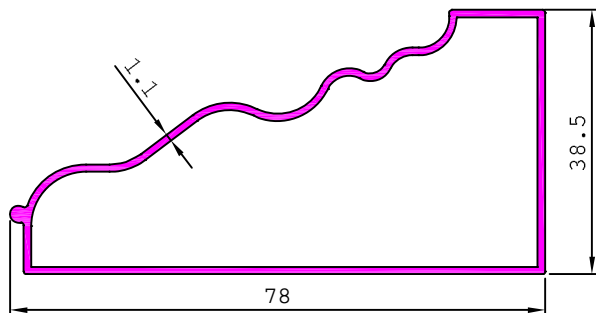

19601 1.481 kg/m

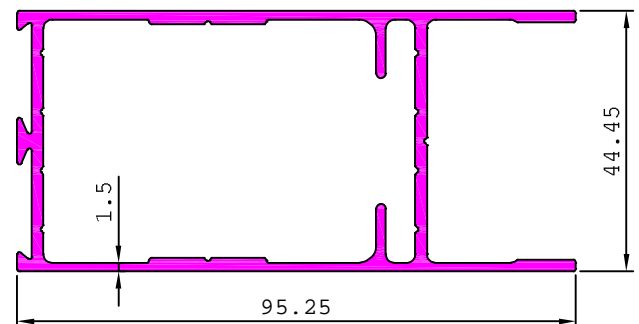

DOORS SECTIONS

19602

1.581 kg/m

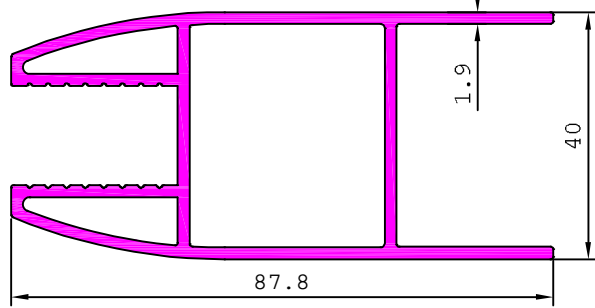

19603

0.529 kg/m

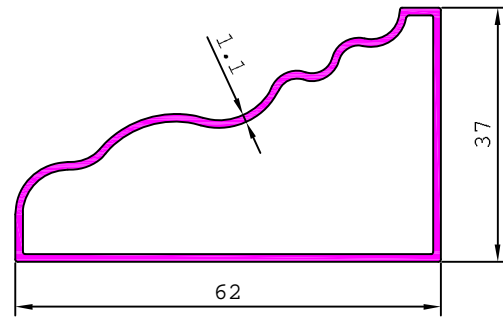

19604

0.655 kg/m

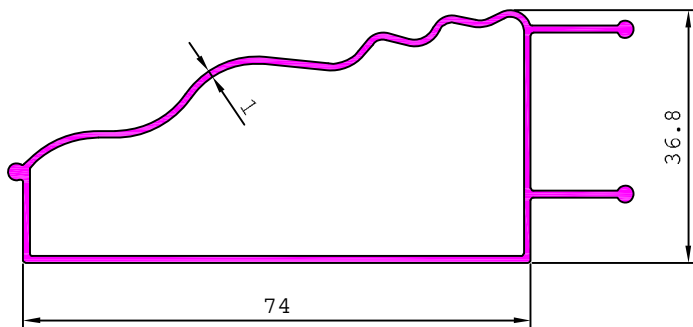

19605

0.552 kg/m

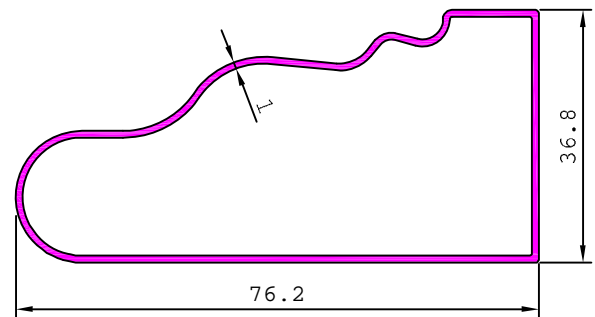

19606

0.434 kg/m

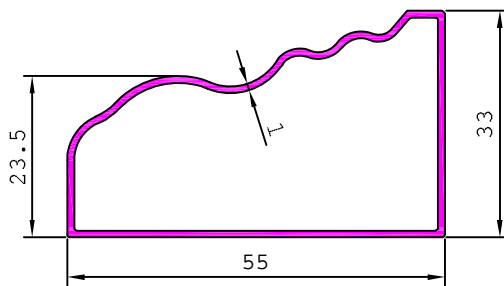

19609

0.974 kg/m

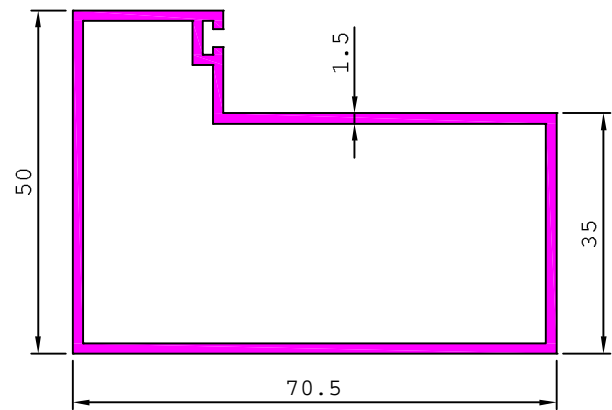

19608

1.626 kg/m

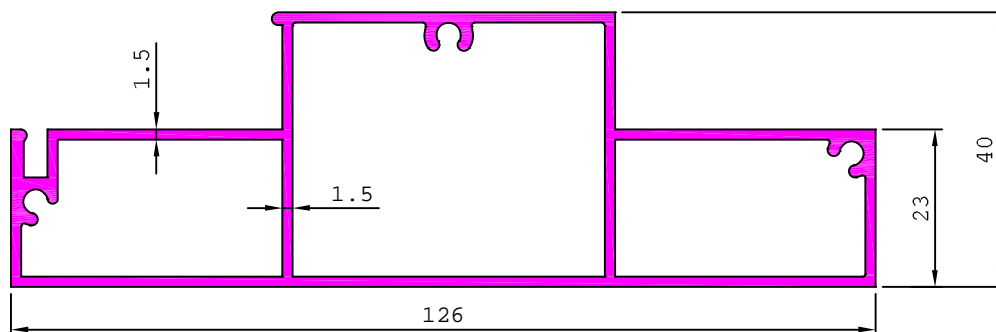

DOORS SECTIONS

19610

1.753 kg/m

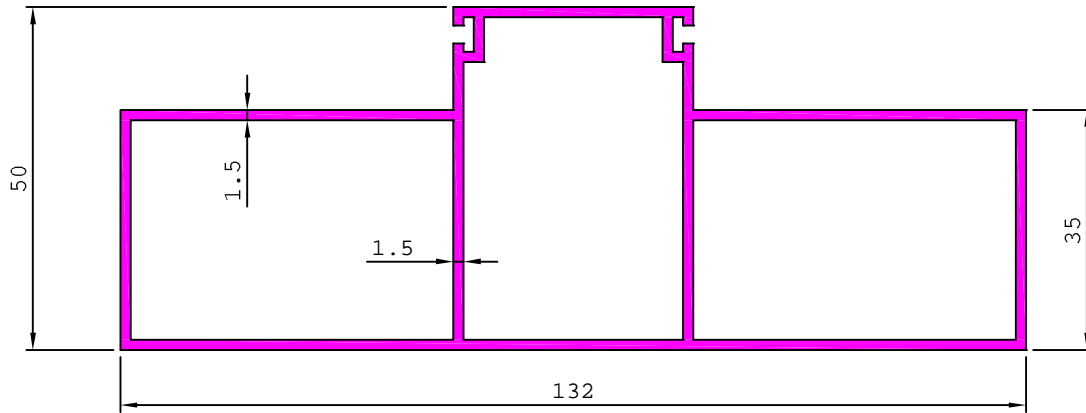

19611

1.527 kg/m

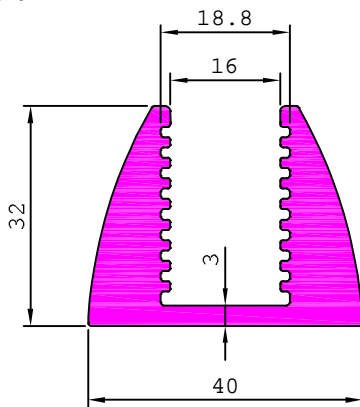

PARTITION SECTION

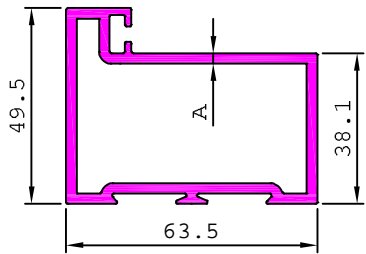

SL. No.	Section No.	A	Weight kg/m
1	20130	1.40	0.947
2	20024	1.70	1.158
3	20001	2.65	1.657

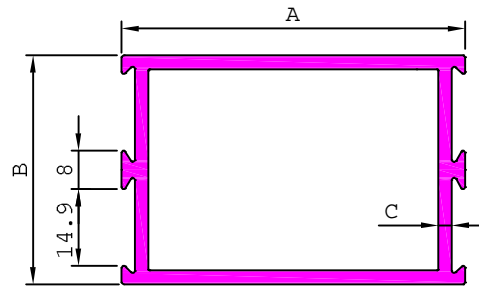

SL. No.	Section No.	A	B	C	Weight kg/m
1	20006	25.00	44.45	2.40	0.918
2	20042	49.91	44.45	0.98	0.607
3	20086	49.91	44.45	1.30	0.753
4	20060	49.91	44.45	2.01	1.072
5	20014	49.91	44.45	3.00	1.495
6	20111	83.50	44.45	2.11	1.497
7	20002	150.00	44.45	2.65	2.786

20012 0.886 kg/m

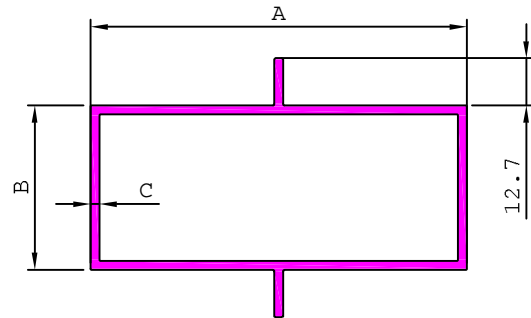
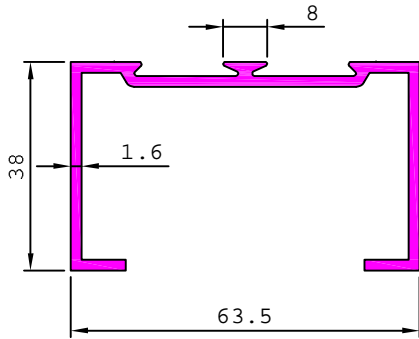

SL. No.	Section No.	A	B	C	Weight kg/m
1	20009	82.50	38.10	3.00	2.062
2	20007	101.60	44.45	2.40	1.995
3	20101	101.60	44.45	3.18	2.617

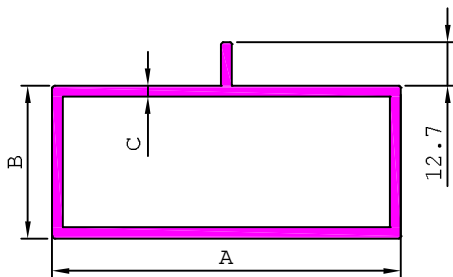

SL. No.	Section No.	A	B	C	Weight kg/m
1	20013	82.50	38.10	3.00	1.959
2	20074	101.60	44.45	2.45	1.951
3	20008	101.60	44.45	3.18	2.508

20019 2.655 kg/m

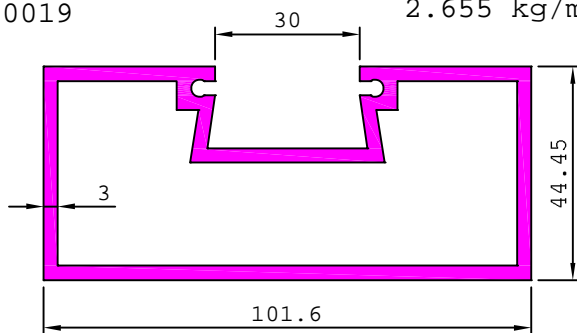

20020 2.818 kg/m

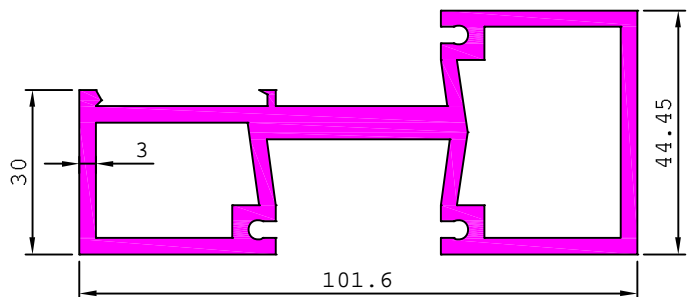

PARTITION SECTION

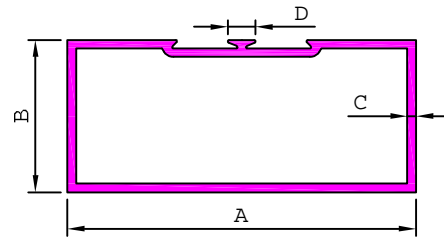
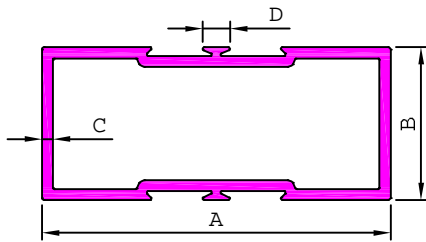

SL. No.	Section No.	A	B	C	D	Weight kg/m
1	20089	47.80	24.00	0.59	7.50	0.316
2	20050	50.80	25.40	0.63	7.50	0.350
3	20044	50.80	25.40	0.79	7.50	0.414
4	20079	50.80	25.40	0.98	7.50	0.496
5	20031	50.80	25.40	1.19	7.50	0.581
6	20017	50.80	25.40	1.34	8.00	0.651
7	20046	63.50	38.10	0.66	7.50	0.455
8	20069	63.50	38.10	0.83	7.50	0.547
9	20034	63.50	38.10	0.92	7.50	0.593
10	20053	63.50	38.10	1.08	7.50	0.686
11	20026	63.50	38.10	1.21	7.50	0.761
12	20062	63.50	38.10	1.28	8.00	0.819
13	20047	63.50	38.10	1.53	8.00	0.942
14	20072	63.50	38.10	1.85	8.00	1.095
15	20064	63.50	38.10	2.50	8.00	1.439
16	20004	63.50	38.10	3.18	8.00	1.790
17	20037	82.50	38.00	1.10	8.00	0.829
18	20124	89.00	32.00	1.50	8.00	1.079
19	20035	82.50	38.00	1.60	8.00	1.139
20	20021	89.00	32.00	2.75	8.00	1.905
21	20023	89.00	32.00	2.75	23.00	2.150
22	20051	101.60	44.45	1.20	8.00	1.060
23	20028	101.60	44.45	1.50	8.00	1.301
24	20076	101.60	44.45	1.93	8.00	1.608
25	20075	101.60	44.45	2.40	8.00	1.954
26	20057	101.60	44.45	2.50	8.00	2.050
27	20066	101.60	44.45	3.00	8.00	2.415
28	20010	101.60	44.45	3.18	8.00	2.683
29	20113	101.60	44.45	3.60	8.00	2.849
27	20081	123.00	44.45	1.50	8.00	1.456

SL. No.	Section No.	A	B	C	D	Weight kg/m
1	20088	47.80	24.00	0.60	7.50	0.274
2	20058	50.00	25.00	2.00	8.00	0.849
3	20049	50.80	25.40	0.73	7.50	0.342
4	20043	50.80	25.40	0.91	7.50	0.414
5	20080	50.80	25.40	1.09	7.50	0.489
6	20030	50.80	25.40	1.30	8.00	0.581
7	20016	50.80	25.40	1.50	8.00	0.651
8	20045	63.50	38.10	0.75	7.50	0.455
9	20068	63.50	38.10	0.92	7.50	0.546
10	20033	63.50	38.10	1.01	7.50	0.595
11	20054	63.50	38.10	1.17	7.50	0.681
12	20027	63.50	38.10	1.31	8.00	0.758
13	20063	63.50	38.10	1.41	8.00	0.818
14	20125	63.50	38.10	1.50	8.00	0.861
15	20048	63.50	38.10	1.65	8.00	0.942
16	20073	63.50	38.10	1.95	8.00	1.092
17	20065	63.50	38.10	2.50	8.00	1.369
18	20005	63.50	38.10	3.18	8.00	1.777
19	20038	82.50	38.00	1.20	8.00	0.829
20	20036	82.50	38.00	1.70	8.00	1.139
21	20032	89.00	32.00	2.75	8.00	1.810
22	20022	89.00	32.00	2.75	23.00	1.933
23	20126	92.00	29.50	1.15	7.50	0.794
24	20128	92.00	32.00	1.30	8.00	0.910
25	20052	101.60	44.45	1.27	8.00	1.049
26	20029	101.60	44.45	1.60	8.00	1.301
27	20078	101.60	44.45	2.01	8.00	1.605
28	20077	101.60	44.45	2.47	8.00	1.950
29	20102	101.60	44.45	2.50	8.00	1.977
30	20067	101.60	44.45	3.00	8.00	2.342
31	20011	101.60	44.45	3.18	8.00	2.541
32	20112	101.60	44.45	3.70	8.00	2.846
33	20059	123.00	44.45	1.50	8.00	1.394

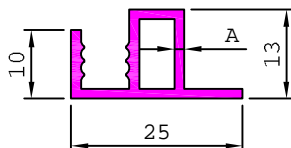

SL. No.	Section No.	A	Weight kg/m
1	20107	1.44	0.246
2	20105	1.50	0.255
3	20121	1.20	0.210