

## SERIES - R

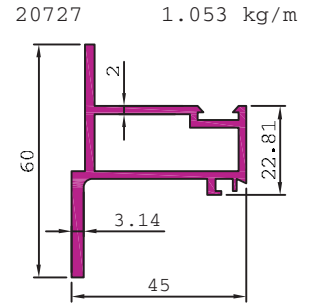

## SERIES - Z

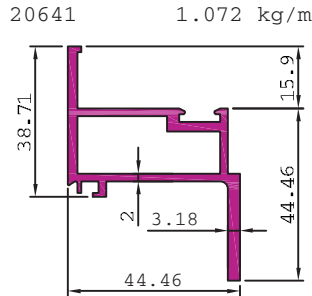
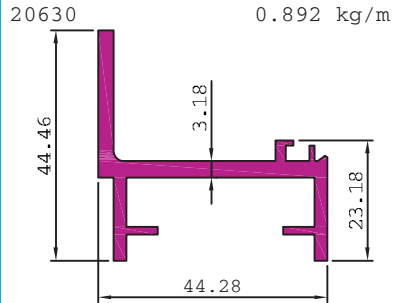
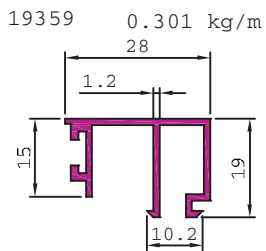
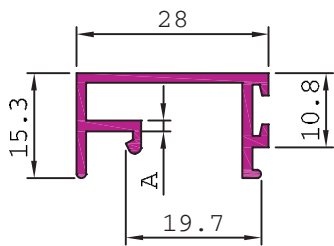

SL. No.	Section No.	A	Weight kg/m
1	19392	1.11	0.224
2	19391	1.50	0.289

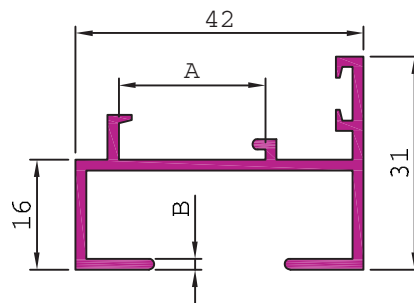

SL. No.	Section No.	A	B	Weight kg/m
1	20942	22.10	1.25	0.434
2	20558	21.40	1.60	0.534

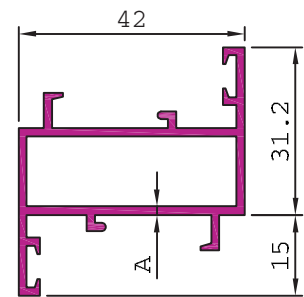

SL. No.	Section No.	A	Weight kg/m
1	20943	1.35	0.651
2	20559	1.50	0.724

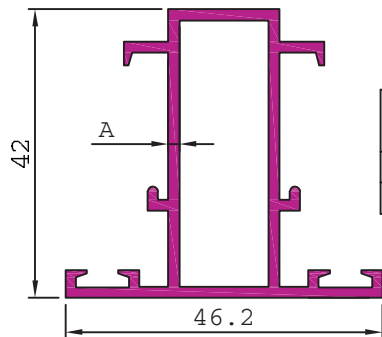

SL. No.	Section No.	A	Weight kg/m
1	20944	1.35	0.651
2	20560	1.60	0.764

## Telephone Series

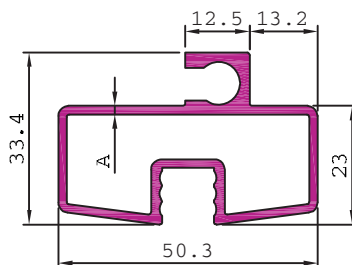
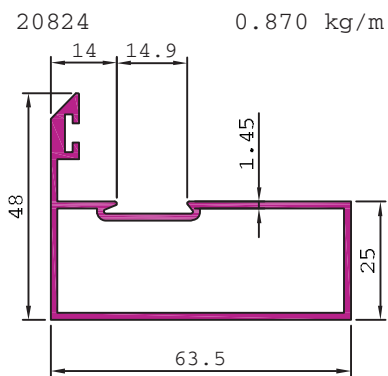

SL. No.	Section No.	A	Weight kg/m
1	20825	1.64	0.854
2	20642	2.00	0.997

