



20 X 54 ECONOMICAL WINDOW SERIES





20 X 54 ECONOMICAL WINDOW SERIES

- All Items are JINDAL make

2 TRACK

SECTION X 2292

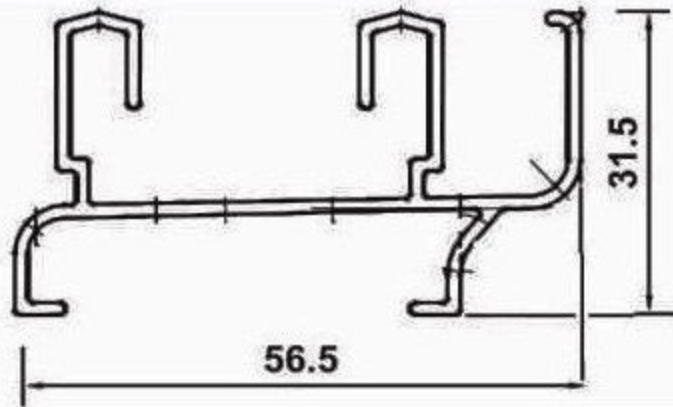

12ft. Weight = 2.300 kgs.

3 TRACK

SECTION X 2291

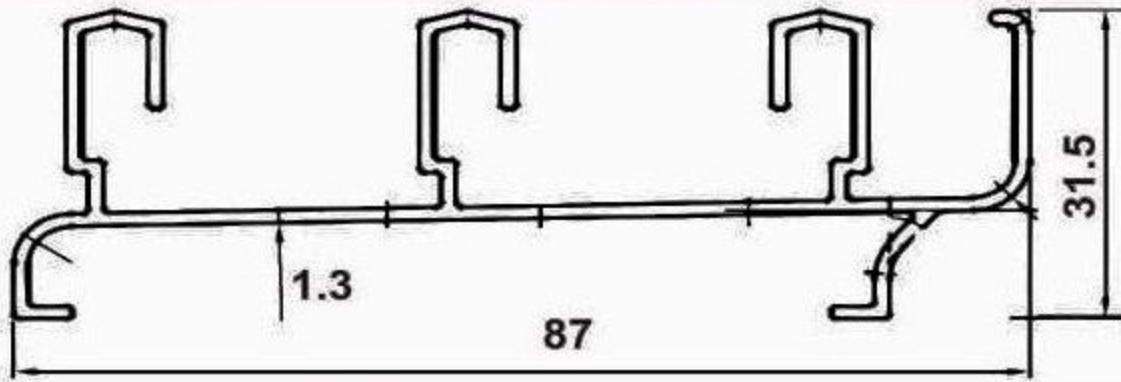

12ft. Weight = 3.100 kgs.

4 TRACK

SECTION X 2290

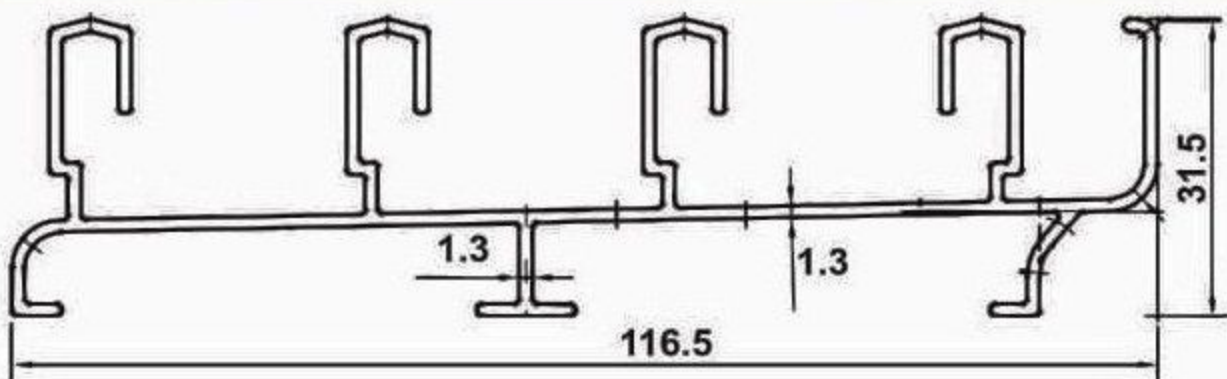

12ft. Weight = 4.200 kgs.



20 X 54 ECONOMICAL WINDOW SERIES

- All Items are JINDAL make

SHUTTER

SECTION X 2293

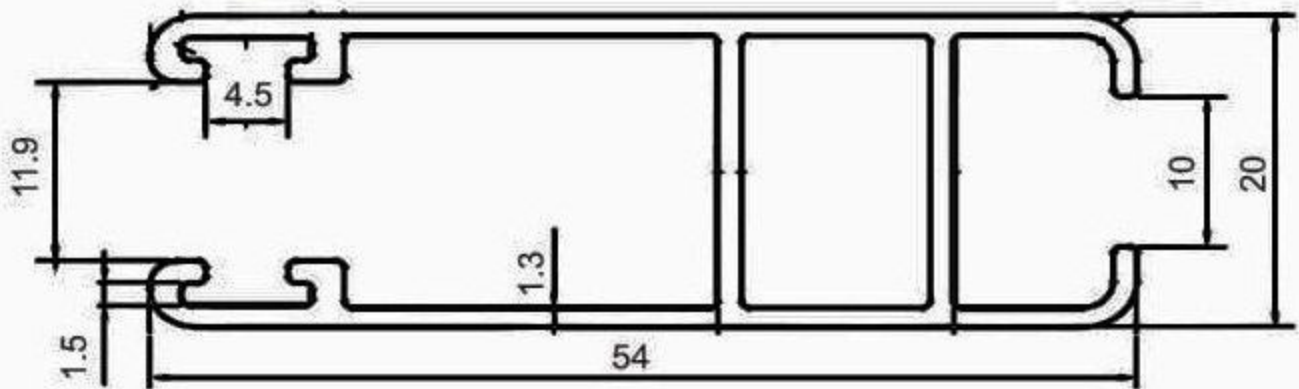

12ft. Weight = 2.300 kgs.

I/L CLIP

SECTION X 2294

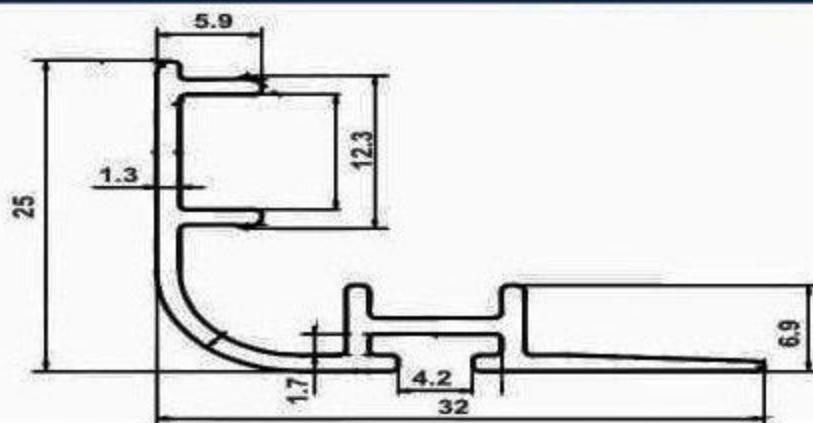

12ft. Weight = 1.000 kgs.



20 X 54 ECONOMICAL WINDOW SERIES

Quality Profile Hardware



SHUTTER JOINTER



**ANTI LIFT
HANDLE**



**INTERLOCK
CAP**



BEARING



20 X 54 ECONOMICAL WINDOW SERIES

Quality Profile Hardware

INTERLOCK
CAP



SHUTTER WING
CONNECTOR



LOCK GUIDE



SLIDING LOCK

- 20 X 54 Costing Prices 1sq. Feet. is similar to 18mm Heavy (3/4-16 Guage)
- 20 X 54 fitting is similar to 27x65 series
- 20 X 54 Economical Series
Max Shutter Dimension 900x2000 mm